

Keystone Showdown

July 18

Showmanship (Small Fry 11 & Under)

SAT.

Show Date: June 16-19, 2022

www.HorseShowPatterns.com

www.HorseShowPatterns.com

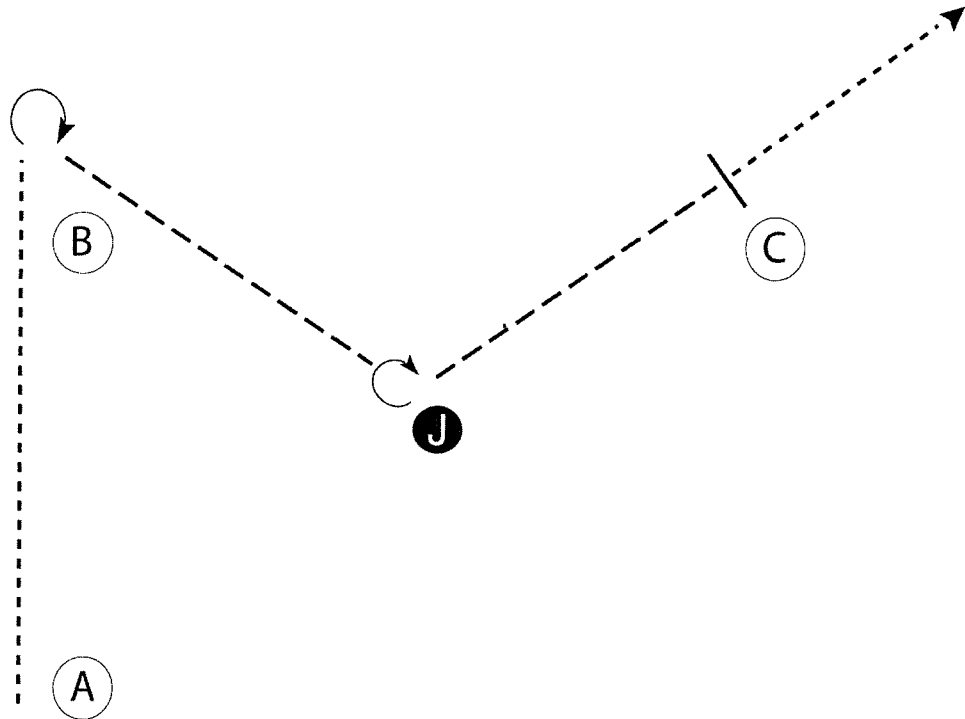

Be ready at A.

1. Walk to and past B.
2. Stop past B, turn 135 degrees and trot to judge.
3. Stop and set up for inspection.
4. When dismissed, do a 3/4 turn and trot to C.
5. Stop at C. When dismissed, walk straight away from C to exit.

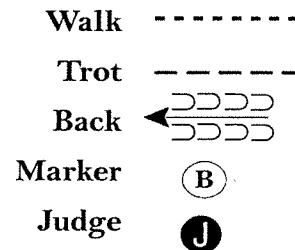

[S/WT-24]

Pattern Provided by:

The Judges

Keystone Showdown

July 18
SAT

Showmanship (L1 Youth and Amateur, 13 & Under)

Show Date: June 16-19, 2022

www.HorseShowPatterns.com

www.HorseShowPatterns.com

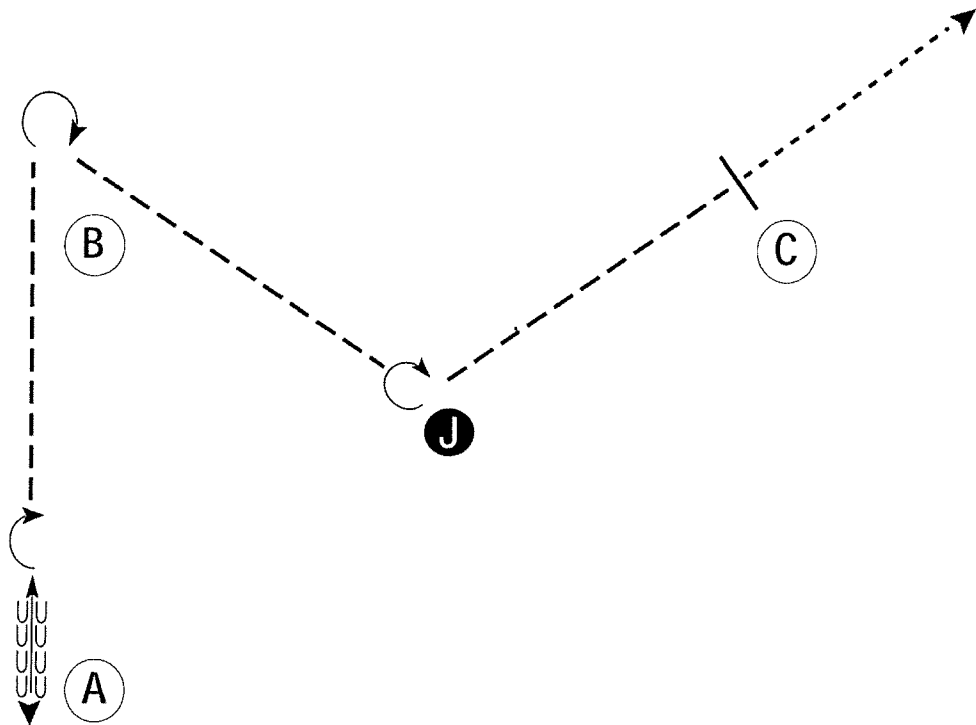

Be ready at A facing away from B.

1. Back one horse length from A.
2. Turn 180 degrees and trot past B.
3. Stop past B, turn 135 degrees and trot to judge.
4. Stop and set up for inspection.
5. When dismissed, do a 3/4 turn and trot to C.
6. Stop at C. When dismissed, walk straight away from C to exit.

| | |
|--------|----------------|
| Walk | ----- |
| Trot | - - - - - |
| Back | ←←←←← ←←←←← |
| Marker | ⊙ B |
| Judge | ● J |

[S/2-24]

Pattern Provided by:

The Judges

Keystone Showdown

July 18

Showmanship (Amateur, 14-18 Youth, Select Amateur) SAT

Show Date: June 16-19, 2022

w w w . H o r s e S h o w P a t t e r n s . c o m

w w w . H o r s e S h o w P a t t e r n s . c o m

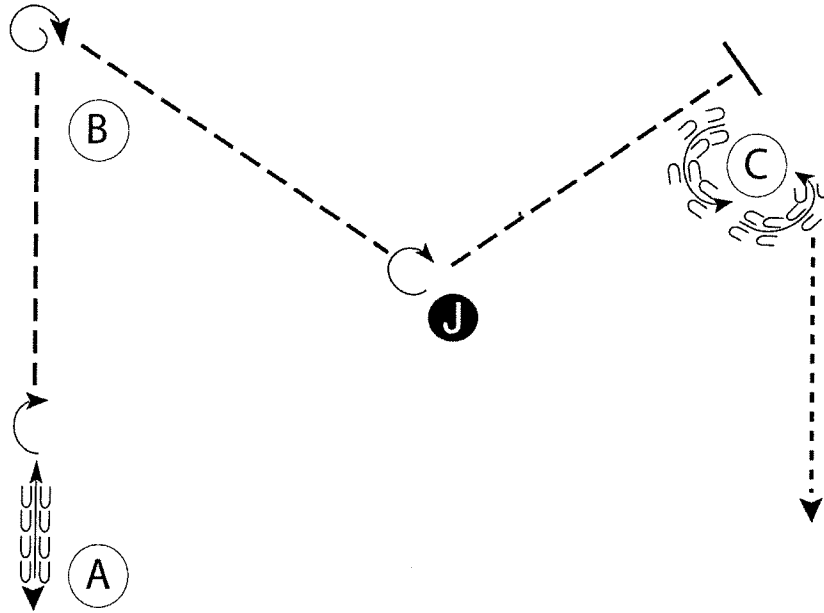

Be ready at A facing away from B.

1. Back one horse length from A.
2. Turn 180 degrees and trot past B.
3. Stop past B, turn 1 1/3 turns and trot to judge.
4. Stop and set up for inspection.
5. When dismissed, do a 3/4 turn and trot to C.
6. Stop at C. Back around C.
7. Walk straight away from C to exit.

| | |
|--------|-------------|
| Walk | ----- |
| Trot | - - - - - |
| Back | ← ⊞ ⊞ ⊞ ⊞ ⊞ |
| Marker | ⊙ B |
| Judge | ● J |

[S/3-24]

Pattern Provided by:

The Judges

Keystone Showdown

June 18

Hunt Seat Equitation (Small Fry 11 & Under)

SAT

Show Date: June 16-19, 2022

Class #50

www.HorseShowPatterns.com

www.HorseShowPatterns.com

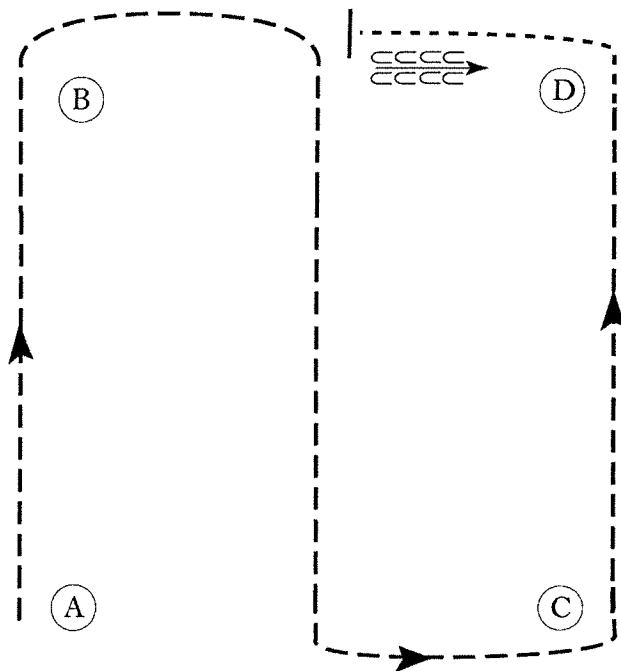

Be ready at A.

1. Posting trot to and around B on the left diagonal.
2. Halfway between B and C, change diagonals.
3. Posting trot on the right diagonal to and around C.
4. Continue to trot to D.
5. At D, walk.
6. Walk until halfway to B, stop and back one horse length.

| | |
|---------------|-----------|
| Walk | ----- |
| Trot | - - - - - |
| Extended Trot | ----- |
| Canter | ===== |
| Leg Yield | |
| Lead Change | ↘ |
| Back | ←←←←← |
| Marker | (B) |
| Sidepass | ←←←←← |
| Hand Gallop | ----- |

[HSE/WT-25]

Pattern Provided by:
The Judges

Keystone Showdown

June 18
SAT

Hunt Seat Equitation (L1 Youth and Amateur, 13 & Under)

Show Date: June 16-19, 2022

www.HorseShowPatterns.com

www.HorseShowPatterns.com

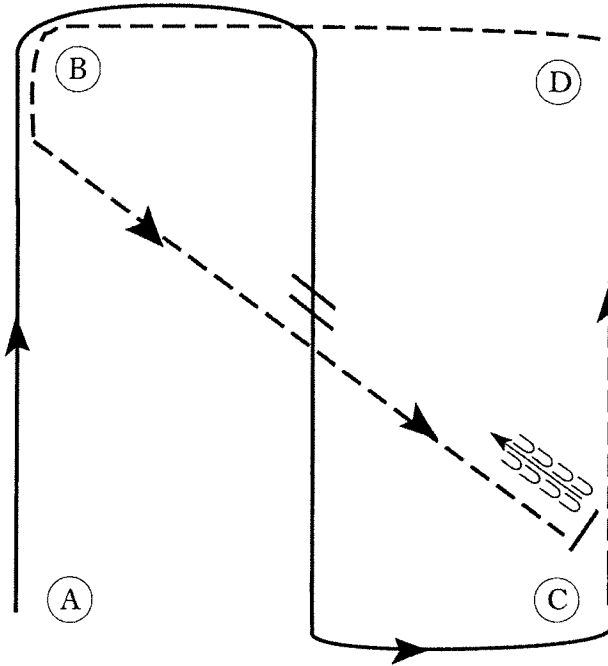

Be ready at A.

1. Canter on the right lead to and around B.
2. Halfway between B and C, change leads.
3. Canter on left lead to and around C.
4. Posting trot on the left diagonal from C to D.
5. At D, change diagonals and continue to trot to B.
6. At B, sitting trot to C.
7. Stop and back one horse length at C.

| | |
|---------------|-----------|
| Walk | ----- |
| Trot | - - - - - |
| Extended Trot | ----- |
| Canter | ----- |
| Leg Yield | |
| Lead Change | /// |
| Back | ←←←←← |
| Marker | (B) |
| Sidepass | ←←←←← |
| Hand Gallop | ----- |

[HSE/2-25]

Pattern Provided by:

The Judges

Keystone Showdown

July 18
SAT

Hunt Seat Equitation (Amateur, 14-18 Youth, Select Amateur)

Show Date: June 16-19, 2022

www.HorseShowPatterns.com

www.HorseShowPatterns.com

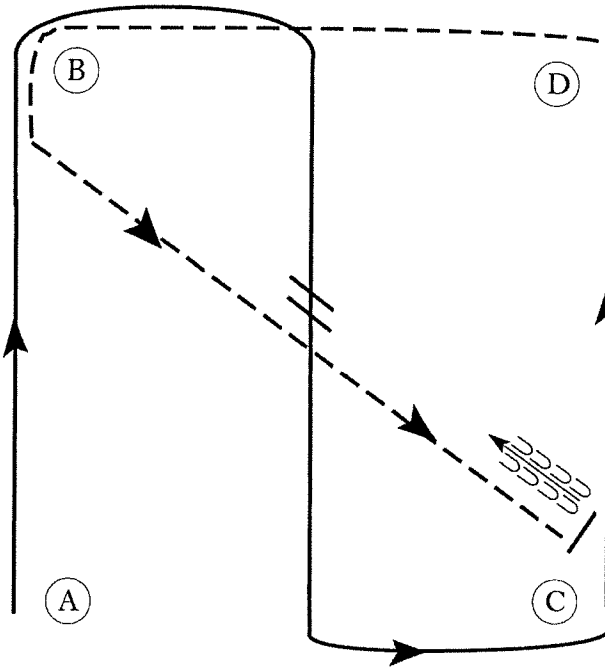

Be ready at A.

1. Canter on the right lead to and around B.
2. Halfway between B and C, change leads.
3. Canter on left lead to and around C.
4. Hand gallop from C to D.
5. At D, perform a posting trot on the right diagonal.
6. At B, two point at the trot until halfway to C.
7. Sitting trot to C.
8. Stop and back one horse length at C.

| | |
|---------------|-----------|
| Walk | ----- |
| Trot | - - - - - |
| Extended Trot | — — — — |
| Canter | — — — — |
| Leg Yield | |
| Lead Change | /// |
| Back | ←←←← |
| Marker | (B) |
| Sidepass | ←←←← |
| Hand Gallop | — — — — |

[HSE/3-25]

Pattern Provided by:
The Judges

Set June 16

Class 500

Small Fry Ranch Riding -

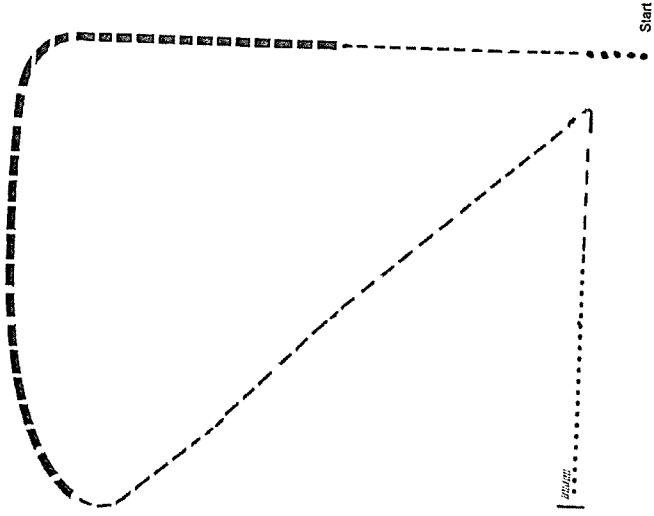

1. Walk
2. Trot
3. Extended Trot
4. Trot
5. Walk
6. Stop & Back

RANCH RIDING - PATTERN 3

Sept 6/18

Open, Youth, Amateur
Jr Sr

LEGEND

| | |
|-------|---------------|
| | Walk |
| ... | Extended Walk |
| - - - | Trot |
| - - - | Extended Trot |
| — | Lope |
| — | Extended Lope |
| //// | Back |
| | Lead Change |

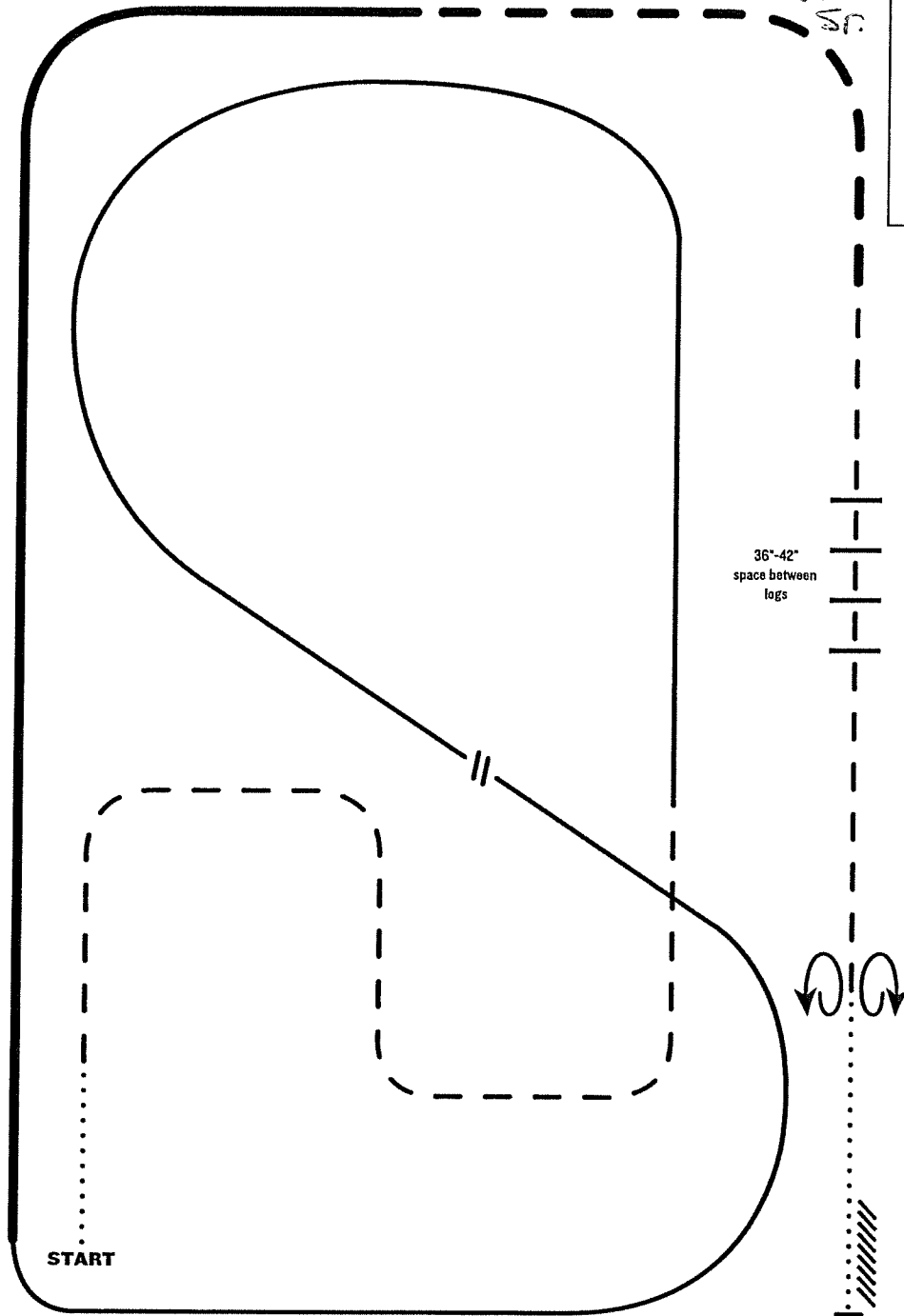

1. Walk
2. Trot serpentine
3. Lope left lead around the end of the arena and then diagonally across the arena
4. Change leads (simple or flying)
5. Lope right lead around end of the arena
6. Extend lope on the straight away and around corner to the center of the arena
7. Extend trot around corner of the arena
8. Collect to a trot
9. Trot over logs
10. Stop, 360° turn each direction (either direction 1st) (L-R or R-L)
11. Walk, stop and back

Note: The drawn description of this pattern is only intended for the general depiction of the pattern. Exhibitors should utilize the arena space to best exhibit their horses.

RANCH RIDING - PATTERN 15

SAT 6/18

Novice Youth

Novice Amateur

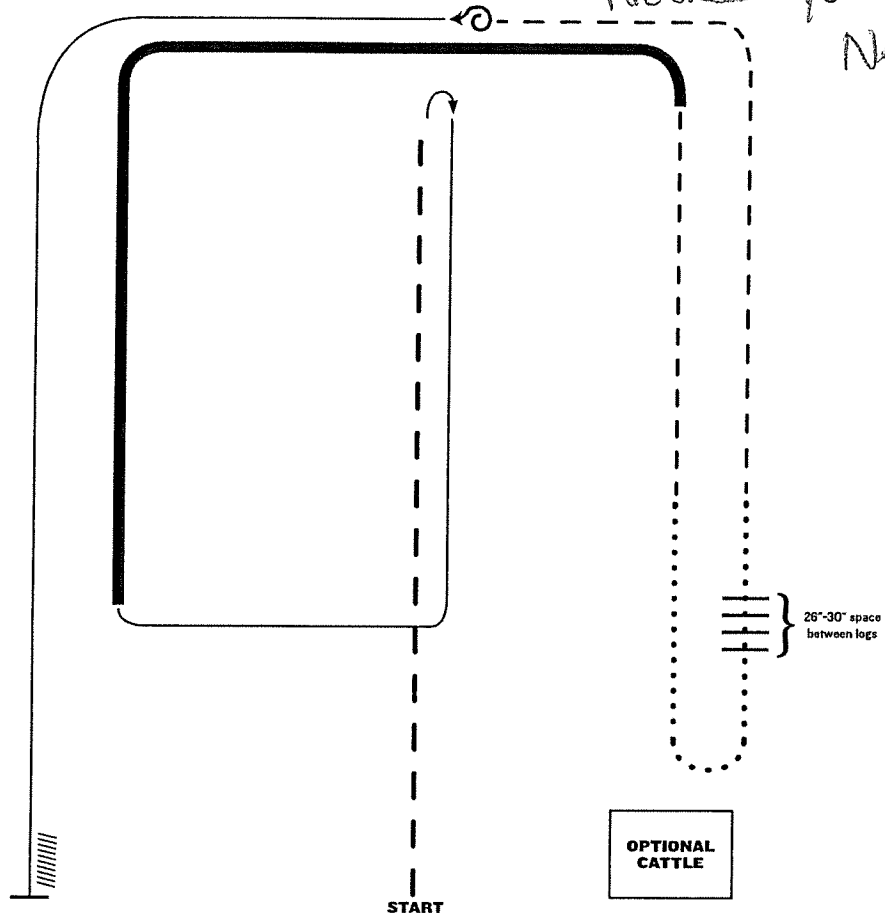

1. Extended trot
2. Stop, rollback right
3. Lope right lead
4. Extended lope (right lead)
5. Trot
6. Walk
7. Walk over logs
8. Walk
9. Trot
10. Stop, 360 left
11. Lope left lead
12. Stop and back

Note: The drawn description of this pattern is only intended for the general depiction of the pattern. Exhibitors should utilize the arena space to best exhibit their horses.

REINING PATTERN 7

Sat July 18
Allreining

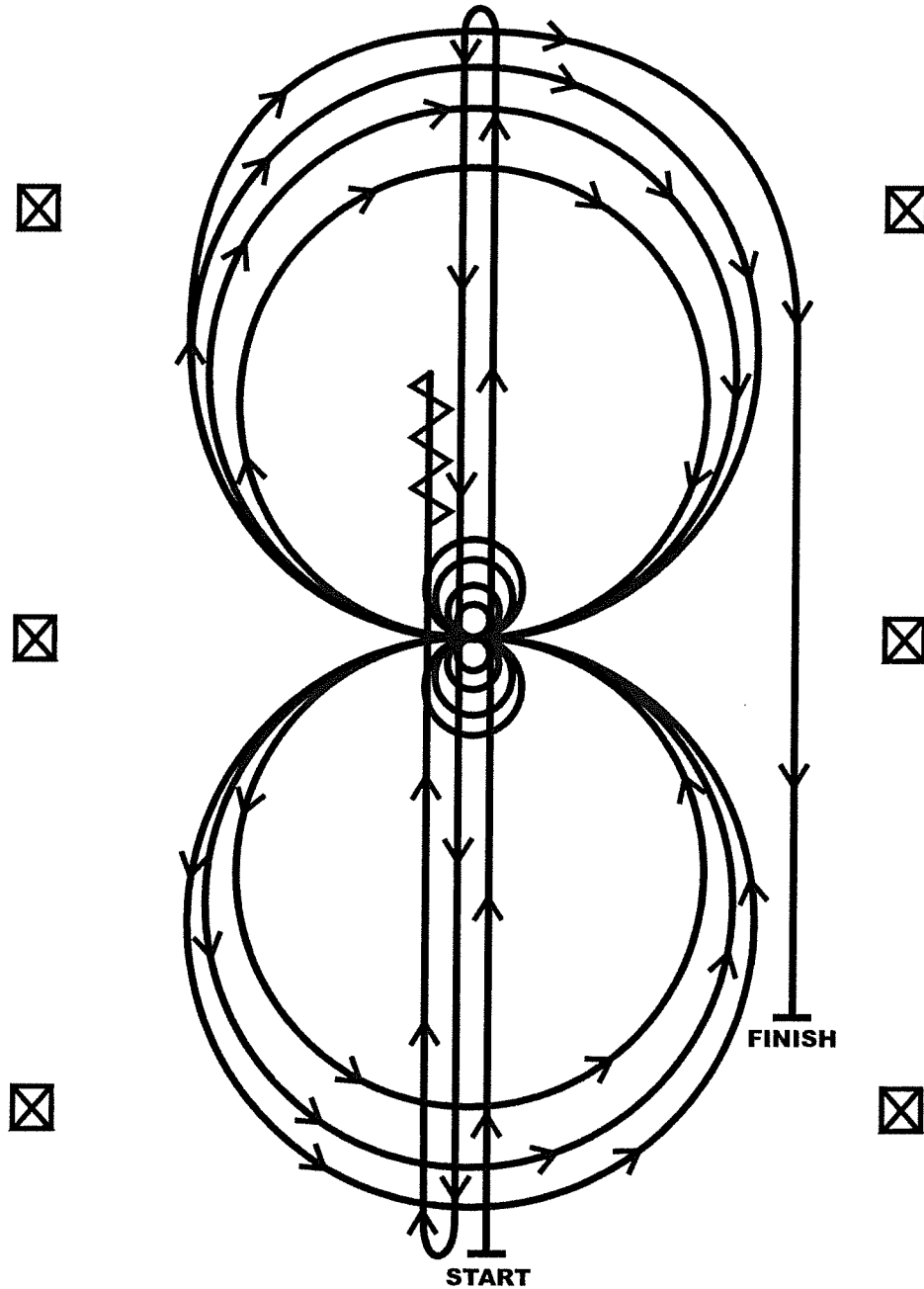

1. Run at speed to the far end of the arena past the end marker and do a left rollback—no hesitation.
2. Run to the opposite end of the arena past the end marker and do a right rollback—no hesitation.
3. Run past the center marker and do a sliding stop. Back up to the center of the arena or at least ten feet (three meters). Hesitate.
4. Complete four spins to the right. Hesitate.
5. Complete four and one-quarter spins to the left so that horse is facing left wall or fence. Hesitate.
6. Beginning on the right lead, complete three circles to the right: the first two circles large fast; the third circle small and slow. Change leads at the center of the arena.
7. Complete three circles to the left: the first two circles large fast; the third circle small and slow. Change leads at the center of the arena.
8. Begin a large circle to the right but do not close this circle. Run straight down the right side of the arena past the center marker and do a sliding stop at least twenty feet (six meters) from the wall or fence. Hesitate to demonstrate completion of the pattern.